

**RZNC-0501 Connection Board**

**Diagram**

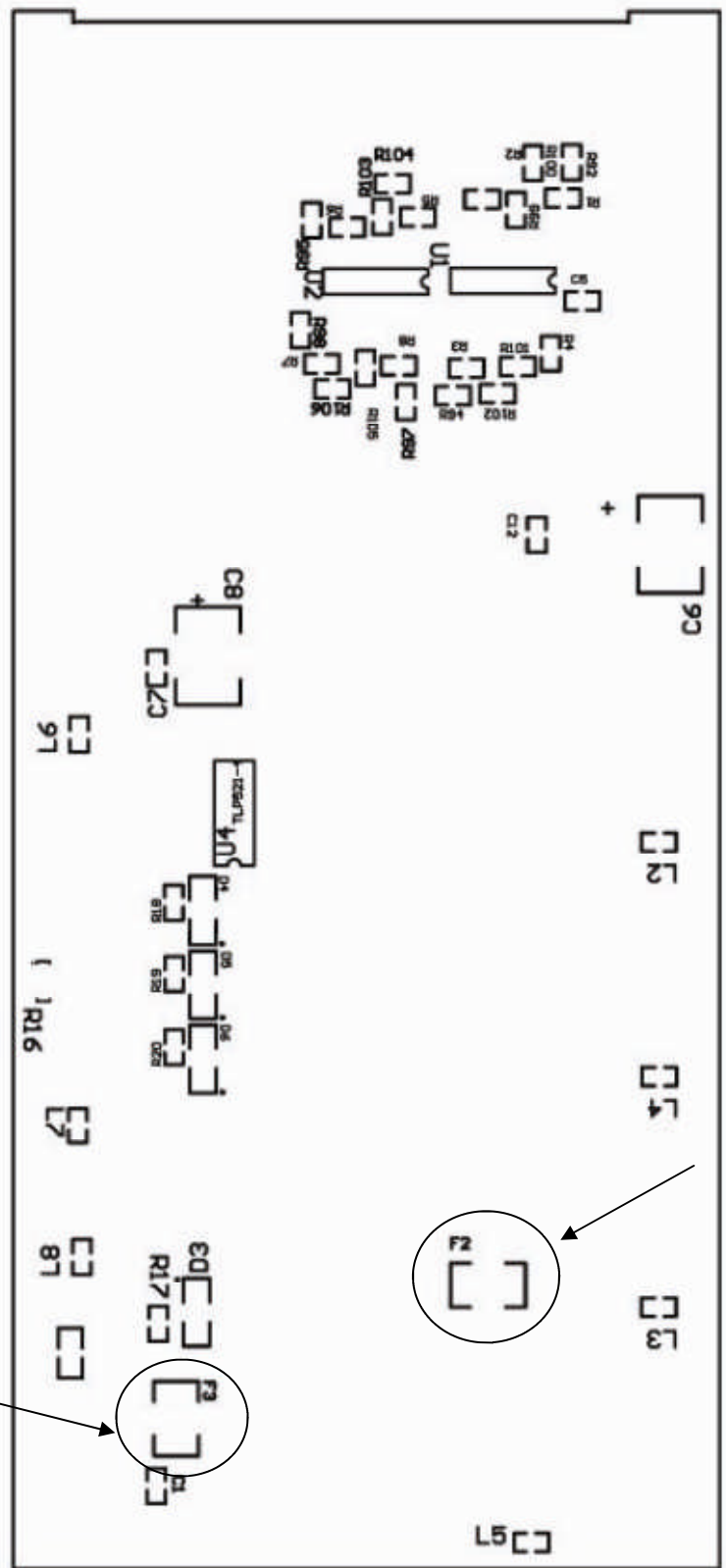





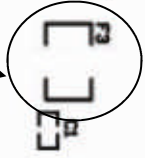

Sensors terminals 24V fuse

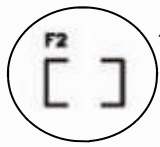

5V positive outputs fuse



No	Terminal	Pin	Pin function	Note
	X Axis Output Terminals	5v+	Positive power terminal of X axis driver □DC5V output	Don't supply any other voltage to this pin
		Pulse	X axis pulse signal output terminal Output Vol $\geq$ 3V Current $\leq$ 8mA	
		DIR	X axis direction signal output terminal Voltage $\geq$ 3V Current $\leq$ 8mA	
		Shielding	X axis driver output shielding line terminal	Don't use this pin as GND
	Y Axis Output Terminals	5v+	Positive power terminal of Y axis driver □DC5V output	Don't supply any other voltage to this pin
		Pulse	Y axis pulse signal output terminal Output Vol $\geq$ 3V Current $\leq$ 8mA	
		DIR	Y axis direction signal output terminal Voltage $\geq$ 3V Current $\leq$ 8mA	
		Shielding	Y axis driver output shielding line terminal	Don't use this pin as GND
	Z Axis Output Terminals	5v+	Positive power terminal of X axis driver □DC5V output	Don't supply any other voltage to this pin
		Pulse	Z axis pulse signal output terminal Output Vol $\geq$ 3V Current $\leq$ 8mA	
		DIR	Z axis direction signal output terminal Voltage $\geq$ 3V Current $\leq$ 8mA	
		Shielding	Z axis driver output shielding line terminal	Don't use this pin as GND
	C Axis Output Terminals	5v+	Positive power terminal of X axis driver □DC5V output	Don't supply any other voltage to this pin
		Pulse	C axis pulse signal output terminal Output Vol $\geq$ 3V Current $\leq$ 8mA	
		DIR	C axis direction signal output terminal Voltage $\geq$ 3V Current $\leq$ 8mA	
		Shielding	C axis driver output shielding line terminal	Don't use this pin as GND



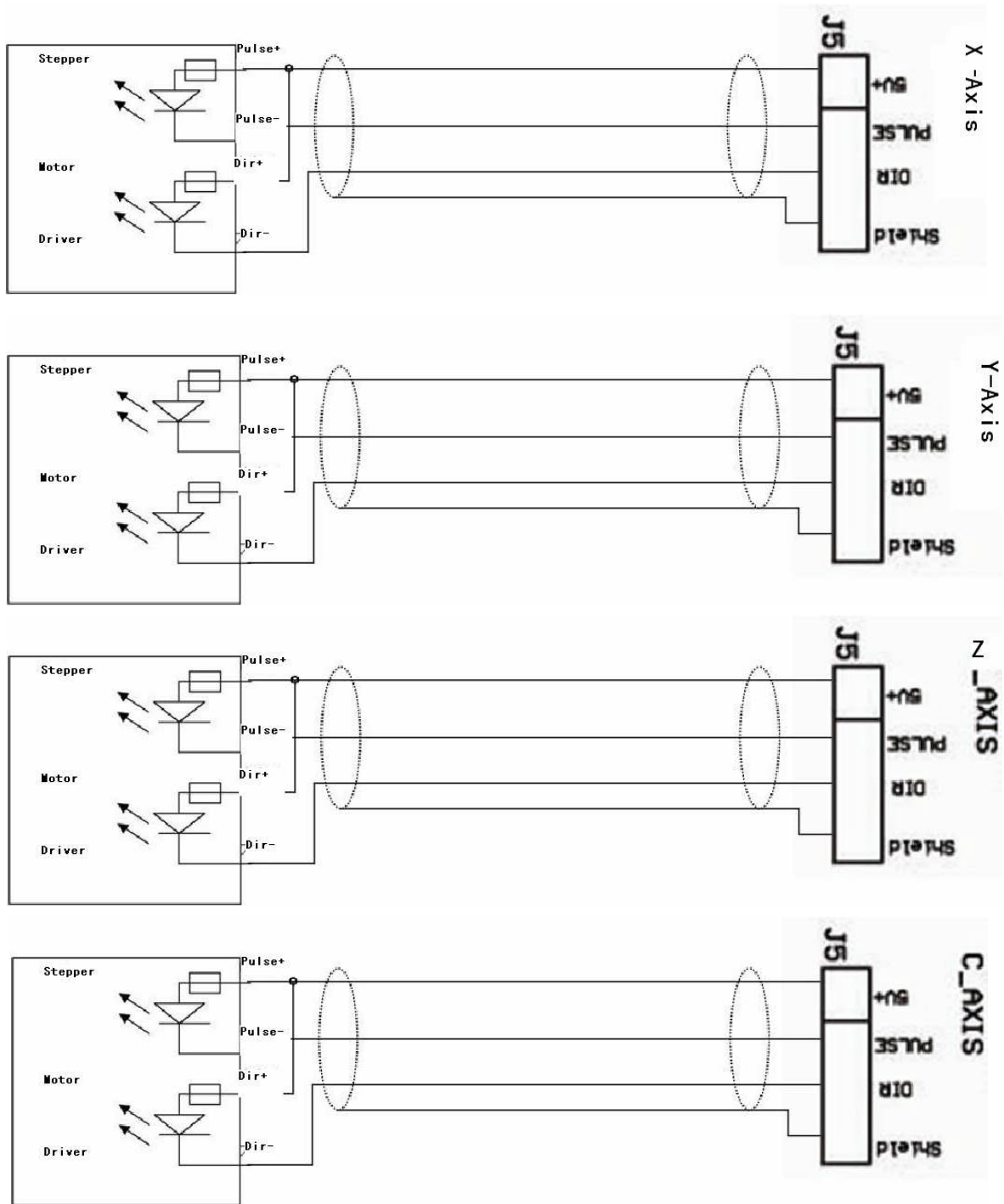

Note: the square pin is the first pin and others No goes as the arrow direction

No	Terminal	Pin	Pin Function	Note
J8	X、Y、Z home sensor terminals	X-Se	Home sensor signal terminal of X axis	It works when this terminal get short circuit with Sensor-
		Y-Se	Home sensor signal terminal of X axis	It works when this terminal get short circuit with Sensor-
		Z-Se	Home sensor signal terminal of X axis	It works when this terminal get short circuit with Sensor-
		Sensor+	Home sensors power+ terminal	Voltage: $\cong$ DC10V $\cong$ DC24V
		Sensor-	Home sensors power- terminal	It can get power from the main power supply when F3 is connected. When F3 is not connected, you should supply power to sensors separately (Default).
		Shielding	Shielding line of home sensors (if there are)	Don't use it as power-.
J9	Cutter Adjust Device (CAD) terminals	Shielding	CAD Shielding line terminal	Don't use it as power-.
		Sensor-	CAD power-	CAD inner power circuit is connected with XYZ home Sensor's.
		CAD signal	CAD signal	
		Sensor+	CAD power+	
J7	Spindle Control	OutputS0	Control spindle speed when it is connected to the inventor	Inner circuit is OC gate. Max Voltage: $\cong$ DC25V Max Current: $\cong$ 400mA.
		OutputS1	Control spindle speed when it is connected to the inventor	
		OutputS2	Control spindle speed when it is connected to the inventor	
		OutputS3	Control spindle speed when it is connected to the inventor	
		SP+	Outputs power+	It is not necessary to supply voltage when it controls spindle speed
		SP-	Output power-	It should be connected to the inventor's COM port when it control spindle speed
		Shielding	Shielding line	Don't use it as power-.

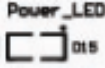

**The diagram between X、Y、Z、C Axes output terminals and Stepper Motor Driver**

Note: the connection lines' diameter should be above 0.3 square mm.  
The shielding line should be connect one end and cut down the other end.

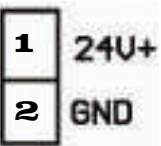
No	Terminal	Pin Definition	Function	Note
	F2	fuse	Pulse signal 5V output overload protection	
	F3	fuse	Sensor overload protection (Current1A)	Default: connected, sensor 24V and main power 24V connects
	D15	Power_led	It shows the main power supply and inner power state	It lights when system gets power
	D14	Indicator	CAD state indicator	They light when signals are short circuit with the Sensor-.
	D13	Indicator	Z axis home sensor state indicator	
	D12	Indicator	Y axis home sensor state indicator	
	D11	Indicator	X axis home sensor state indicator	
	System main power supply	power	Supply power to the controller with DC 5V. When F3 is connected, it also offers voltage to XYZ home sensor terminal.	Voltage: DC10V~DC24V/2A

## Home sensor diagram ( NPN Approaching Sensor )

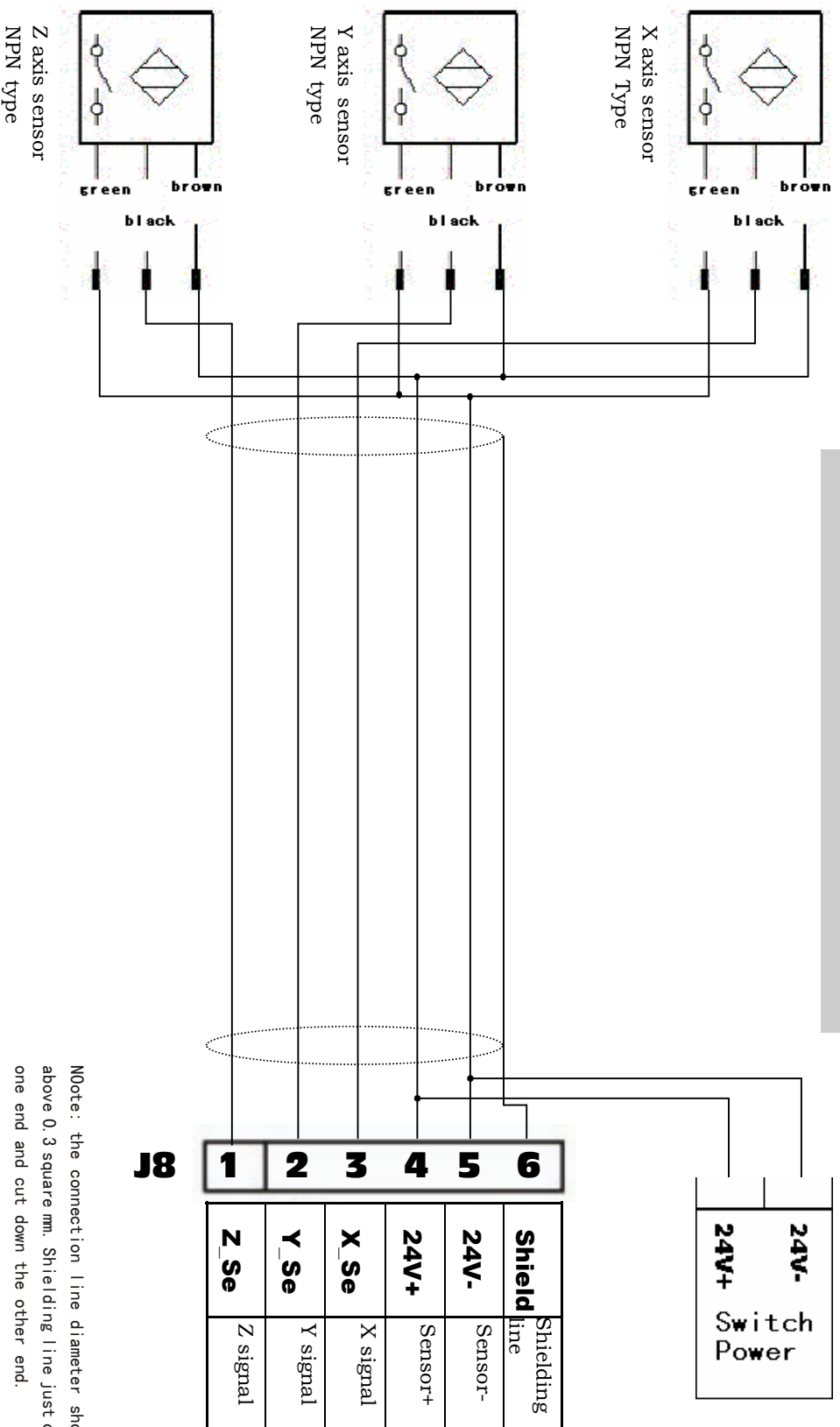

Note: the connection line diameter should be above 0.3 square mm. Shielding line just connect one end and cut down the other end.



# Home Sensors Diagram (Machinery sensor )

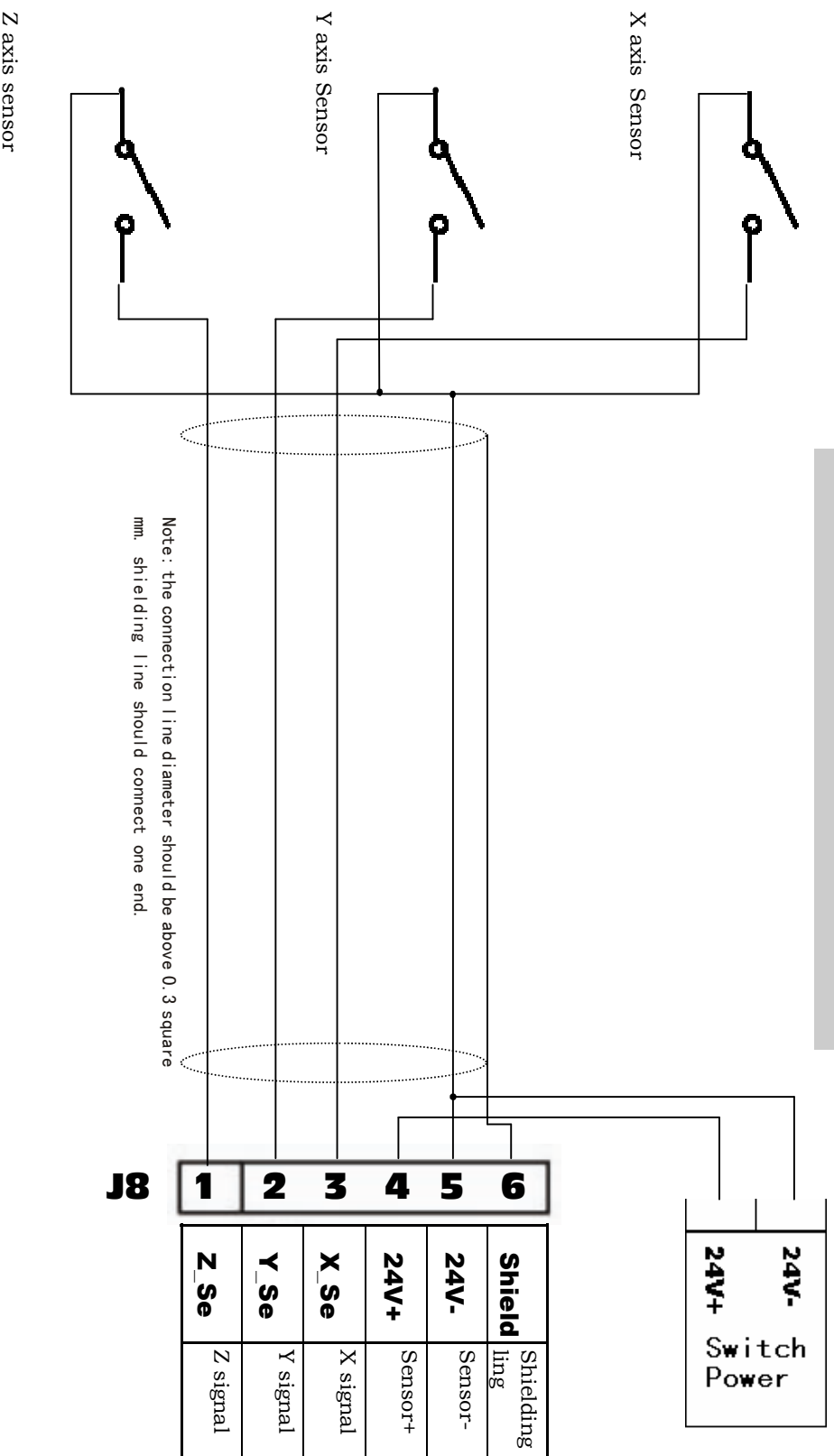

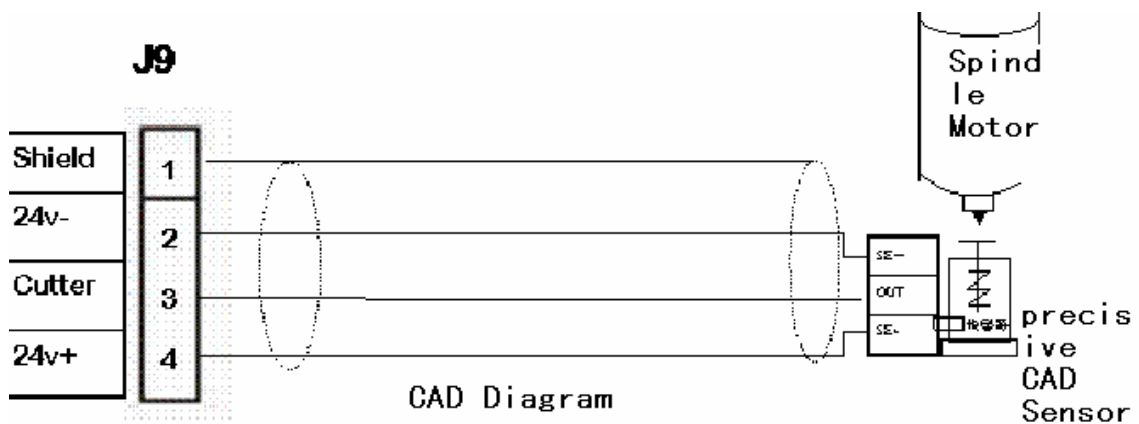
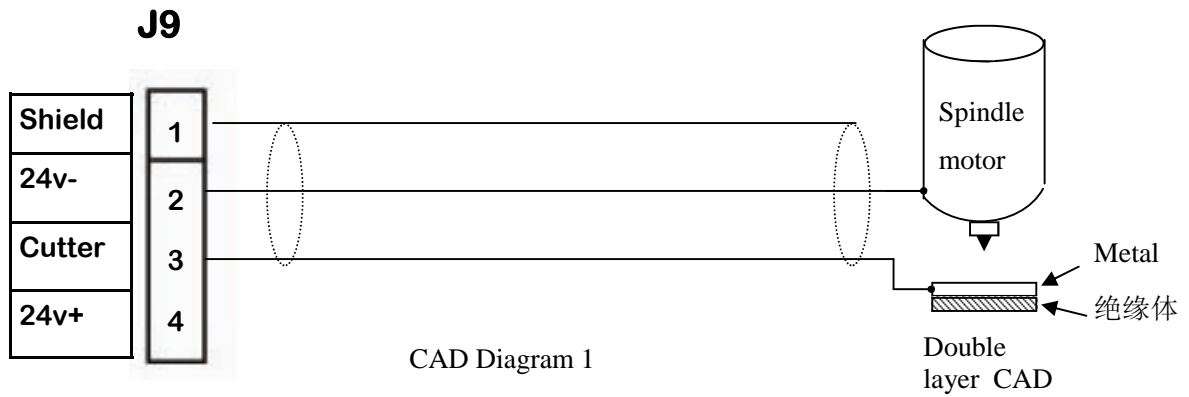

Note: CAD signal lines' diameter should be above 0.3 square mm. Shielding line just connect one end.  
 For CAD diagram 1, the 24V- (Sensor-) should be well connect to spindle motor cover. And do not connect it to the machine fracture.  
 If you adopt precise CAD sensor, please pay attention to the voltage it asks.

Note on Voltage: Because the internal power circuits of CAD, XYZ home sensors and spindle output terminal are connected. If you have offered power to XYZ home sensor terminal, then you need not to give power to CAD or Spindle output terminals.

## J7

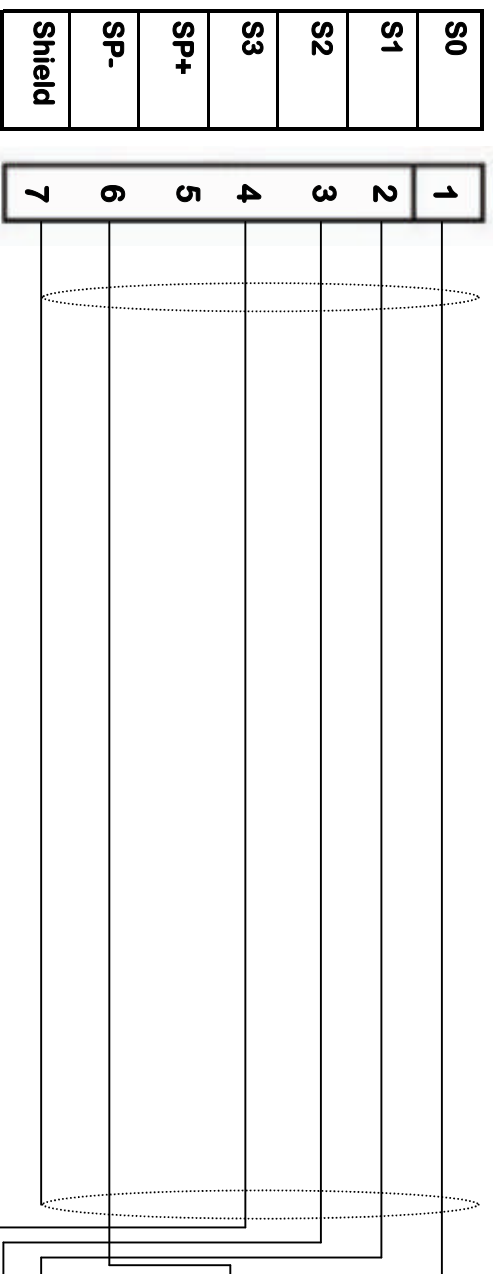

注意事项：图纸标出的信号线均采用屏蔽线连接方式连接，主轴控制信号屏蔽线内芯径应满足0.3平方毫米。对于屏蔽层起始端标出连接位置，而末端未标出的剪断即可，但断面尽量靠近焊接点。主要是为了防止屏蔽层断面离焊接点过长，致使屏蔽线的内芯暴露太长引来干扰。在不使用段速控制只使用主轴起停模式时，只连接S0线和SP-两线既可。

**严禁将主轴控制信号屏蔽层在接口板接地的同时将变频器一端也接与变频器外壳地端。这样连接可能导致主轴电机失控。**

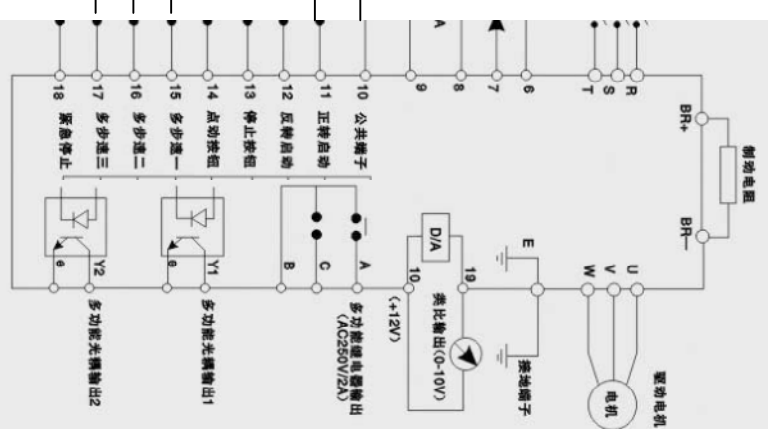

Inventor

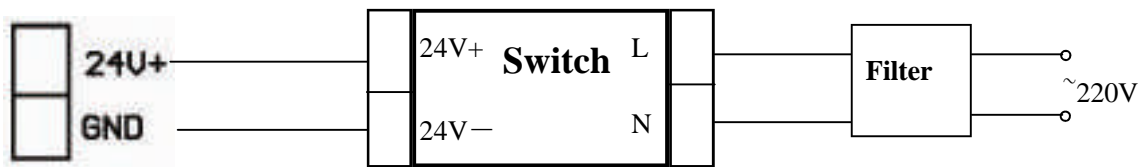

Note: The output voltage should be 24V +/- 5%. The connecting line diameter from the switch to the connection board should be above 0.8 square mm.

Don't connect GND in connection board to any GND ports.

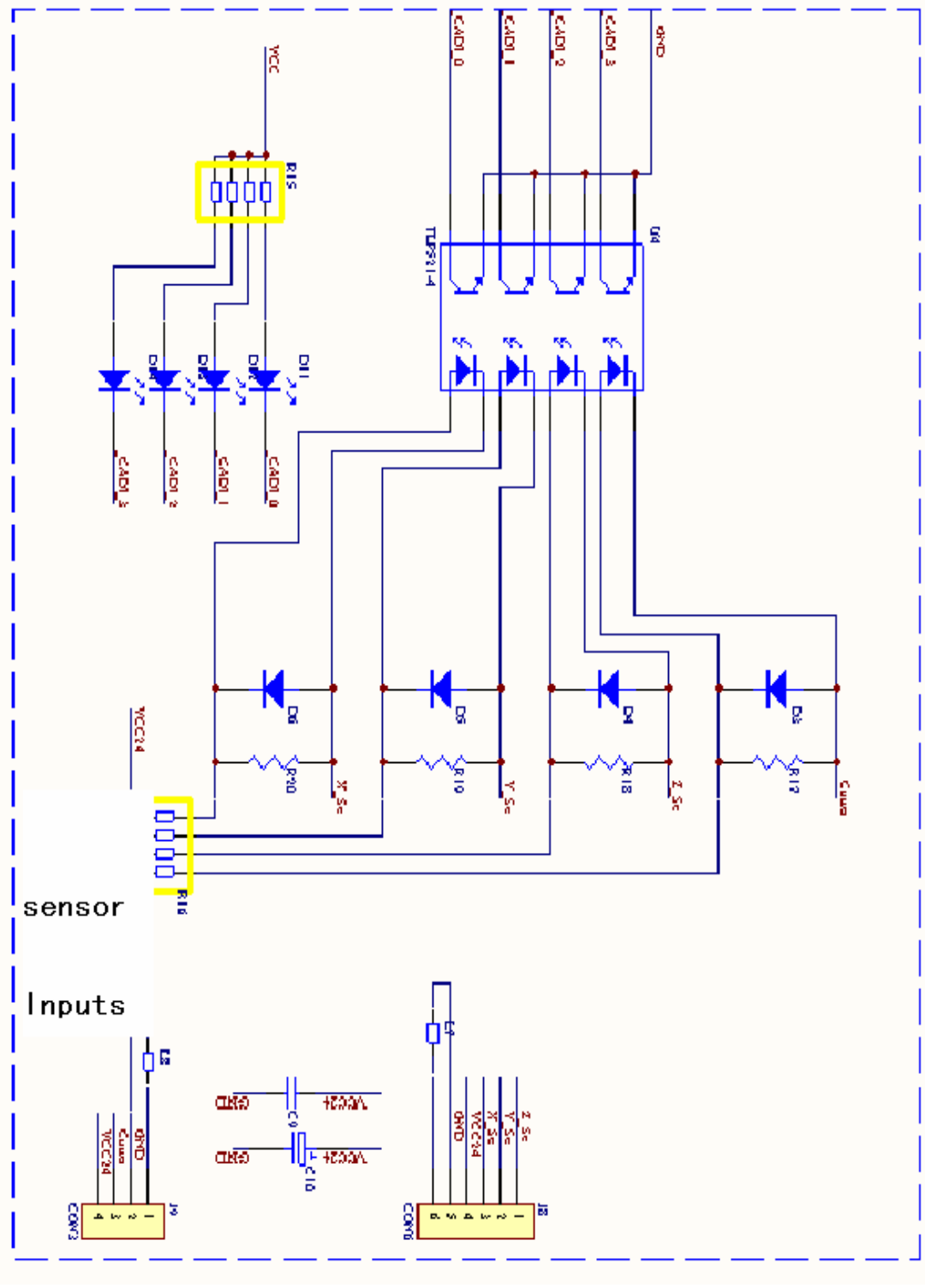

sensor

Inputs

